



# AGRICULTURAL MACHINERY **GEARBOX**

The gearbox has low noise and stable operation. It is made of nodular cast iron with strong toughness and long service life.

Gears and shafts are quenched and have high surface hardness.

Use high-quality oil seals and bearings

Each gearbox can be delivered after passing the inspection.

## **APPLICATION**

Its products are used in a variety of applications, like farm mower, snow sweeper, fertilizer applicator, grain conveyor, industrial equipment, petroleum mining machinery, ship industry equipment, and engineering hydraulic components,

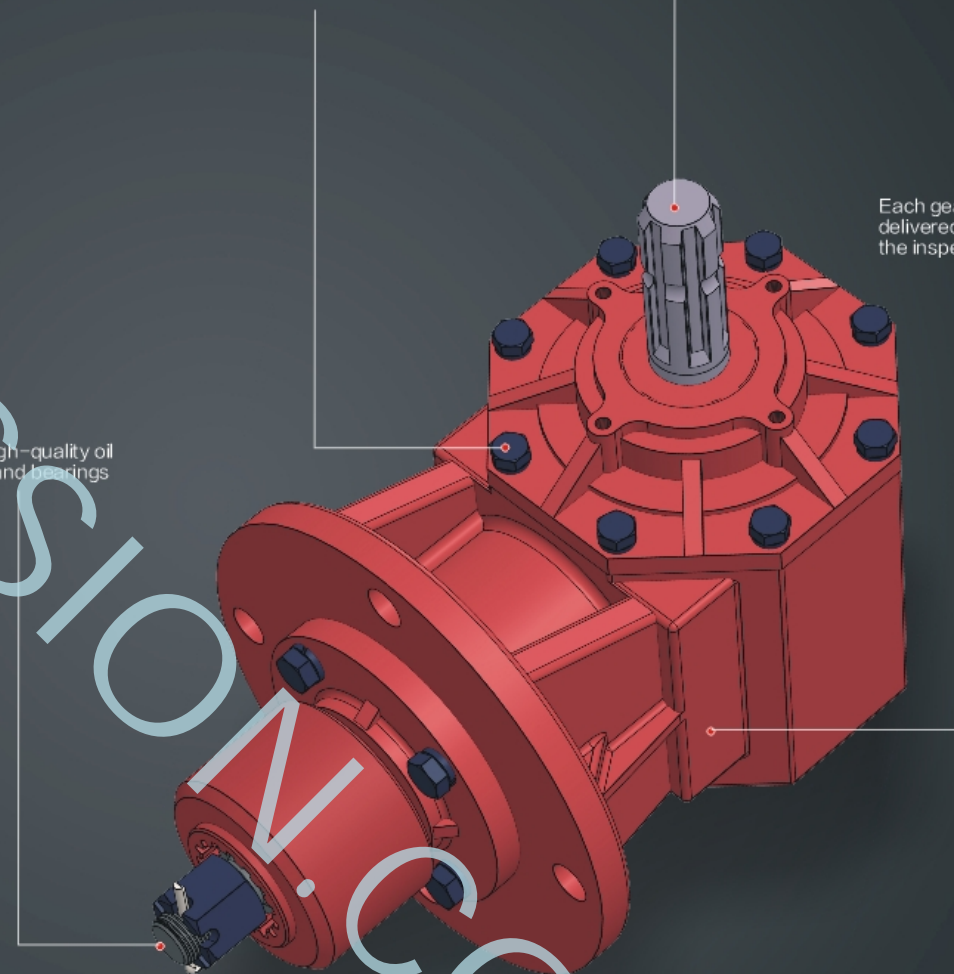

# GEARBOX

Lawn mower series

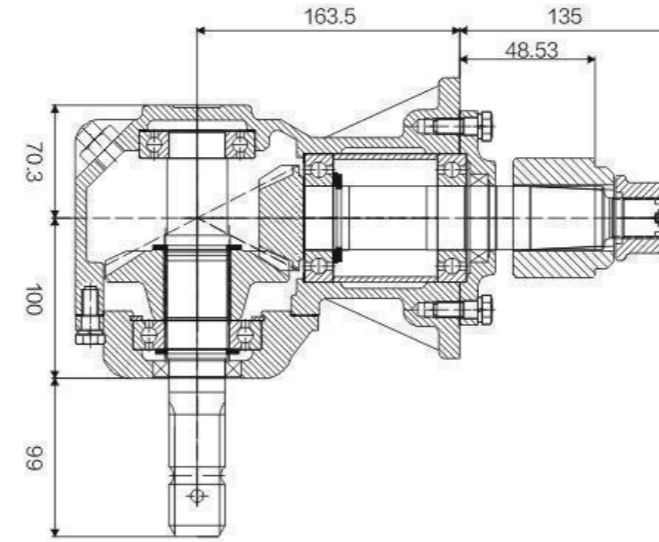
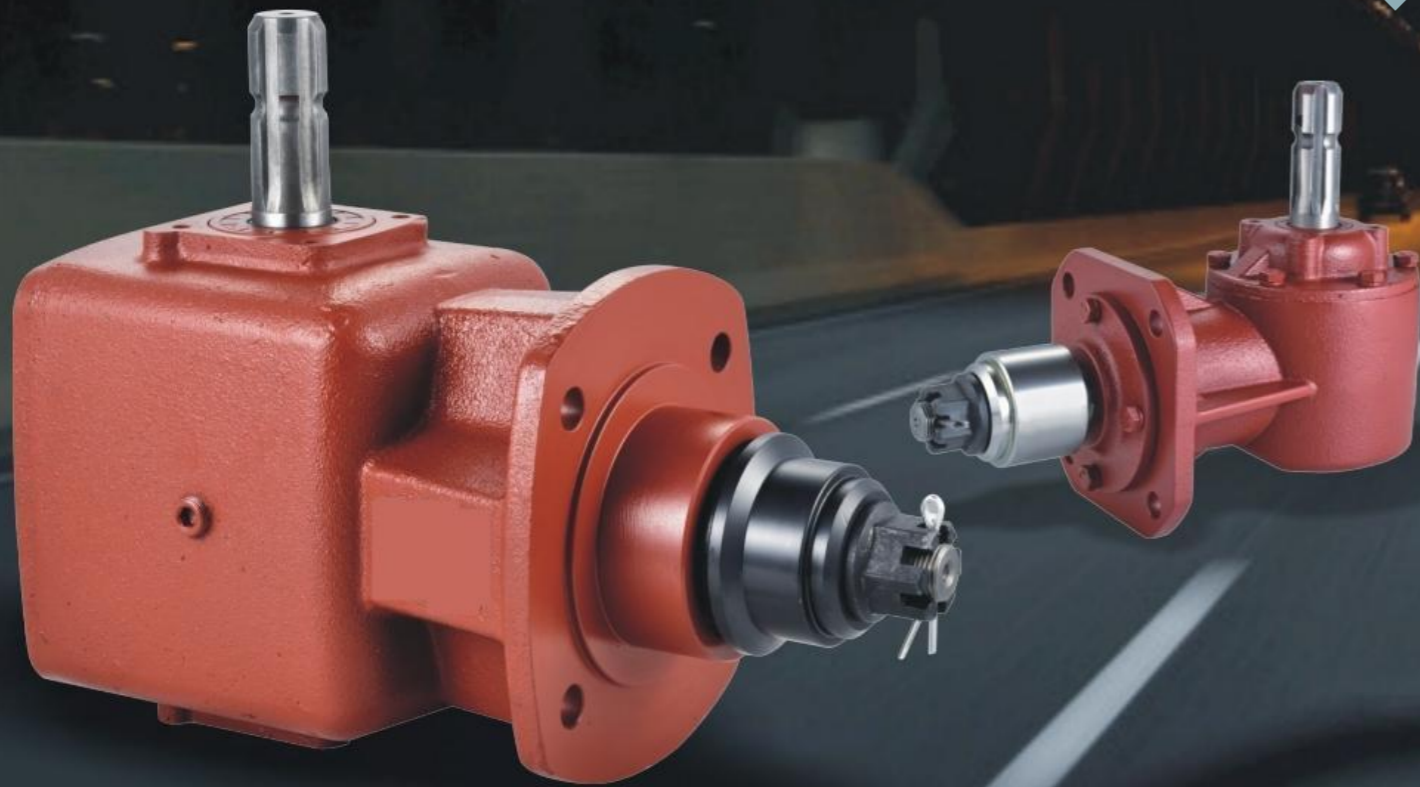

#### PRODUCT PARAMETERS

ITEM	HC-RC31
Ratio	1:1.46/1:1.69 / 1:1.93 / 1:2.3
Teeth	22/15 / 22/13 / 29/15 / 28/12
Module	5.08/5.0 / 4.0 / 4.0
Power(HP)	30
Rated Input	540 rpm
Input/Output Description	3/8 Z6/ Optic axis /Taper spline
Weight(N.W)	21.5Kg



HC-RC31

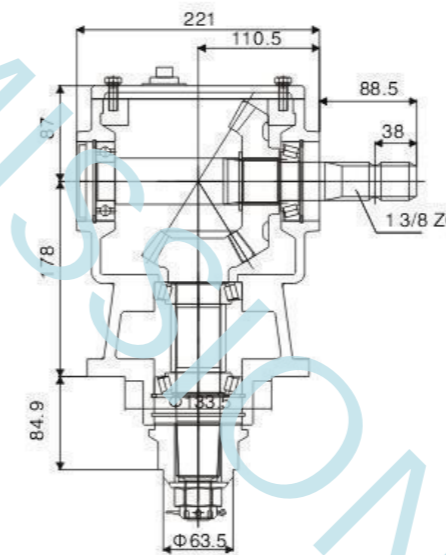

#### PRODUCT PARAMETERS

ITEM	HC-55
Ratio	1:1.6
Teeth	15/24
Module	6.0
Power(HP)	50
Rated Input	540 rpm
Input/Output Description	1 3/8 Z6 Cone base aequilate spline shaft
Weight(N.W)	28.7Kg



HC-55

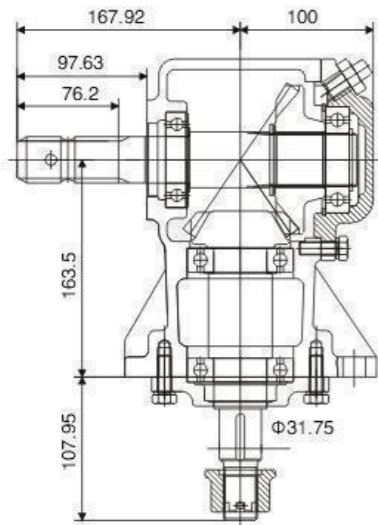

HC-RC30-193

PRODUCT PARAMETERS	
ITEM	HC-RC30-193
Ratio	1:1.93
Teeth	15/29
Module	4.0
Power(HP)	30
Rated Input	540 rpm
Input/Output Description	1 3/8 Z6 Φ31.75 Optic axis
Weight(N.W)	24.5Kg

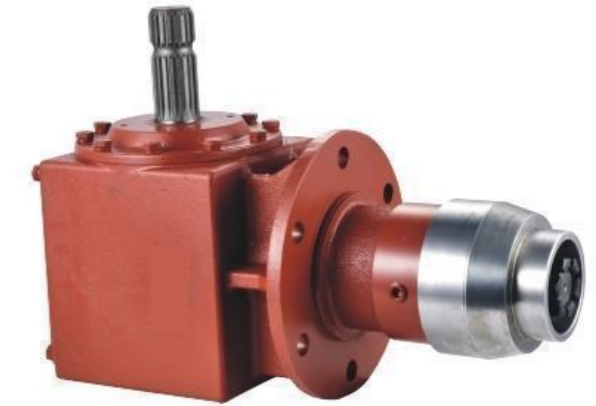
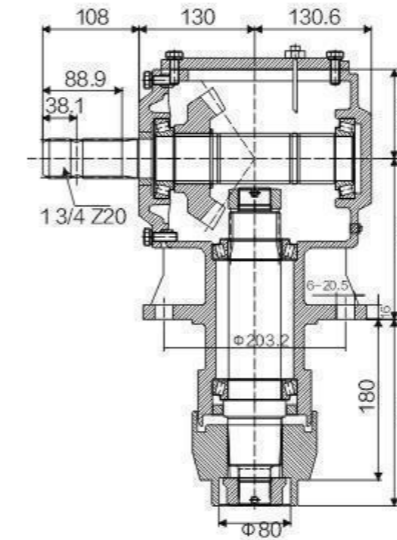

HC-RC130-146

PRODUCT PARAMETERS	
ITEM	HC-RC130-146 / HC-RC130-192
Ratio	1:1.46 / 1:1.92
Teeth	19/13 / 27/14
Module	6 / 8
Power(HP)	130 / 100
Rated Input	540 rpm
Input/Output Description	1 3/4 Z20 / Taper spline
Weight(N.W)	56 Kg

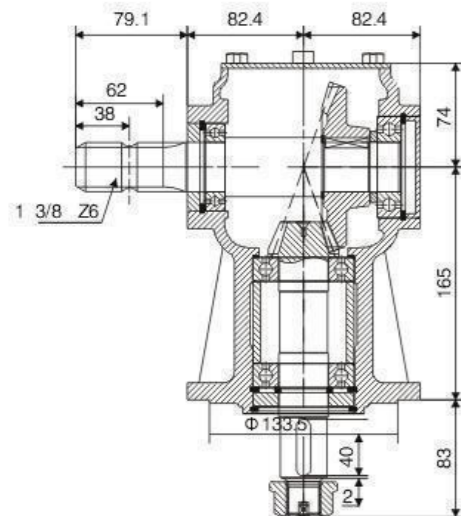

HC-LF211

PRODUCT PARAMETERS	
ITEM	HC-LF211
Ratio	1:2.83
Teeth	34/12
Module	3.36
Power(HP)	20
Rated Input	540 rpm
Input/Output Description	1 3/8 Z6 Optic axis
Weight(N.W)	14.5Kg

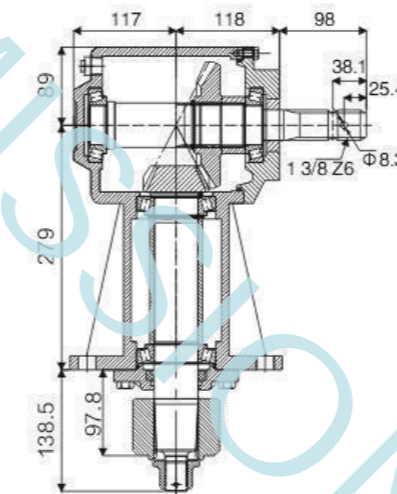

HC-RC81

PRODUCT PARAMETERS	
ITEM	HC-RC81
Ratio	1:1.93 / 1:146
Teeth	27/14 / 19/13
Module	5.5 / 7.0
Power(HP)	80
Rated Input	600rpm
Input/Output Description	1 3/8 Z6 Taper spline
Weight(N.W)	43Kg

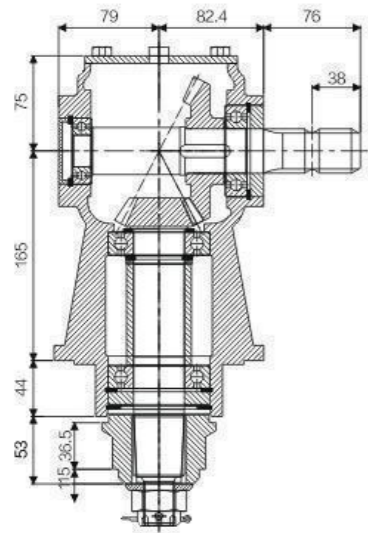

PRODUCT PARAMETERS	
ITEM	HC-LF205
Ratio	1:1.46 / 1:1.93
Teeth	22/15 / 23/12
Module	5.0 / 5.0
Power(HP)	30
Rated Input	540 rpm
Input/Output Description	1 3/8 Z6/Optic axls Taper spline
Weight(N.W)	19Kg

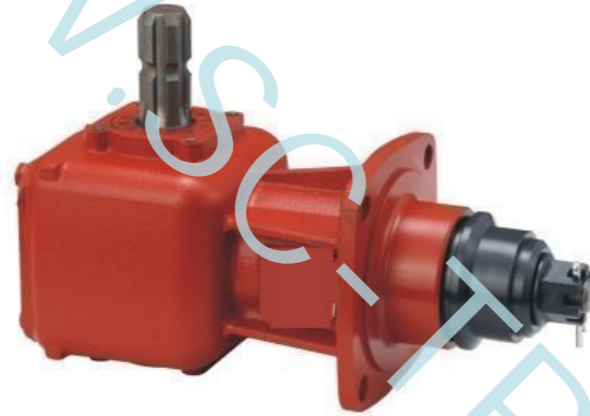

HC-LF205

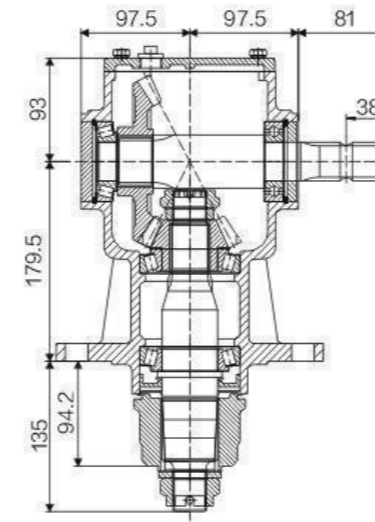

PRODUCT PARAMETERS	
ITEM	HC-140
Ratio	1:1.5 / 1:1.93
Teeth	21/14 / 27/14
Module	5.7 / 5.64
Power(HP)	60
Rated Input	540 rpm
Input/Output Description	1 3/8 Z6 Taper spline
Weight(N.W)	30Kg



HC-140

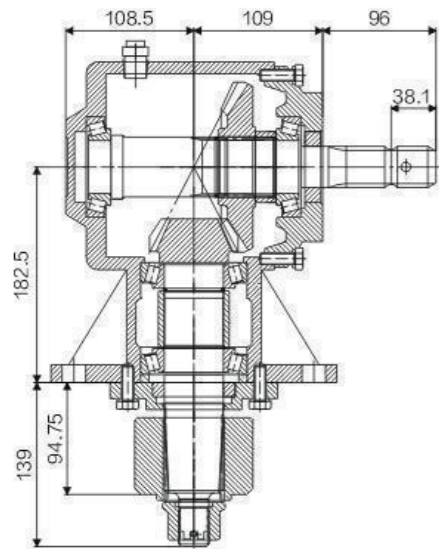

PRODUCT PARAMETERS	
ITEM	HC-RC61
Ratio	1:1.46 / 1:1.93
Teeth	19/13 / 27/14
Module	7.0 / 5.5
Power(HP)	60
Rated Input	540 rpm
Input/Output Description	1 3/8 Z6 Taper spline
Weight(N.W)	36.5Kg



HC-RC61

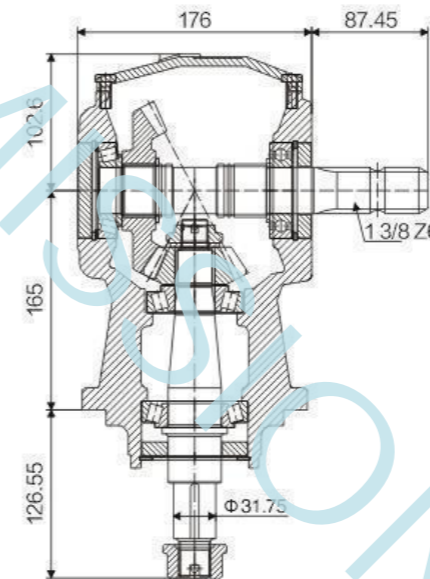

PRODUCT PARAMETERS	
ITEM	HC-01-790 / HC-01-793
Ratio	1:1.92 / 1:2.5
Teeth	25/13 / 30/12
Module	5.25 / 3.9
Power(HP)	40 / 30
Rated Input	540 rpm
Input/Output Description	1 3/8 Z6 / Keyway
Weight(N.W)	23.5 Kg



HC-01-790

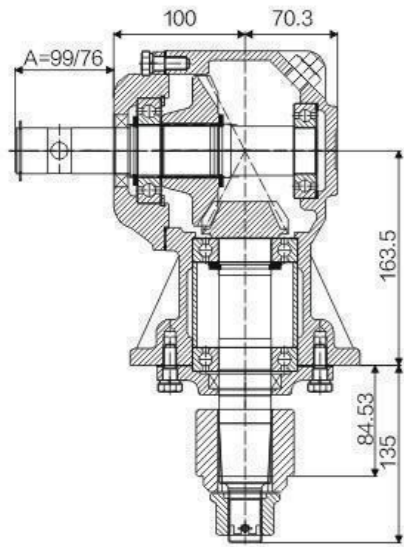

RC31

PRODUCT PARAMETERS

ITEM	RC31
Ratio	1:1.46 / 1:1.69 / 1:1.93 / 1:2.3
Teeth	22/15 / 22/13 / 29/15 / 28/12
Module	5.08 / 5.0 / 4.0 / 4.0
Power(HP)	30
Rated Input	540 rpm
Input/Output Description	3/8 Z6/Optic axis aper spline
Weight(N.W)	21.5Kg

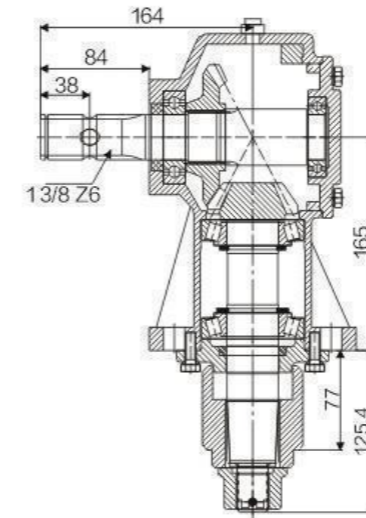

HC-GS4RC

PRODUCT PARAMETERS

ITEM	HC-GS4RC
Ratio	1:1.46 / 1:1.93
Teeth	22/15 / 23/12
Module	5.08 / 5.0
Power(HP)	30
Rated Input	540 rpm
Input/Output Description	13/8 Z6 Taper spline
Weight(N.W)	19Kg

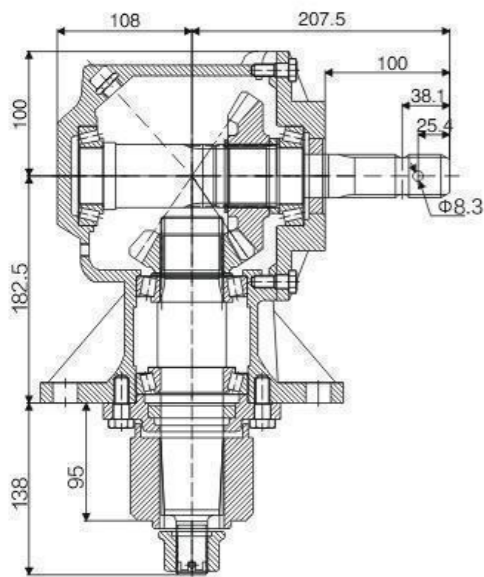

HC-966109

PRODUCT PARAMETERS

ITEM	HC-966109
Ratio	1:1.46 / 1:1.93
Teeth	13/19 / 14/27
Module	7.0 / 5.5
Power(HP)	60
Rated Input	540 rpm
Input/Output Description	1 3/8 Z6/1 3/4 Z20 Optic ax1 STaper spline
Weight(N.W)	36.5Kg

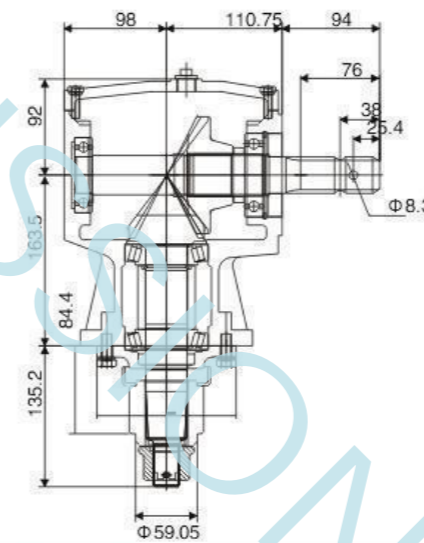

HC-X30

PRODUCT PARAMETERS

ITEM	HC-01-609	HC-01-723	HC-01-611
Ratio	1:1.47	1:1.69	1:1.93
Teeth	15/22	13/22	15/29
Module	5.08	5.0	4.0
Power(HP)	35	35	30
Rated Input	540 rpm	540 rpm	540 rpm
Input/Output Description	1 3/8 Z6 Optic axis Cone base aequilate spline shaft		
Weight(N.W)	26.5Kg		

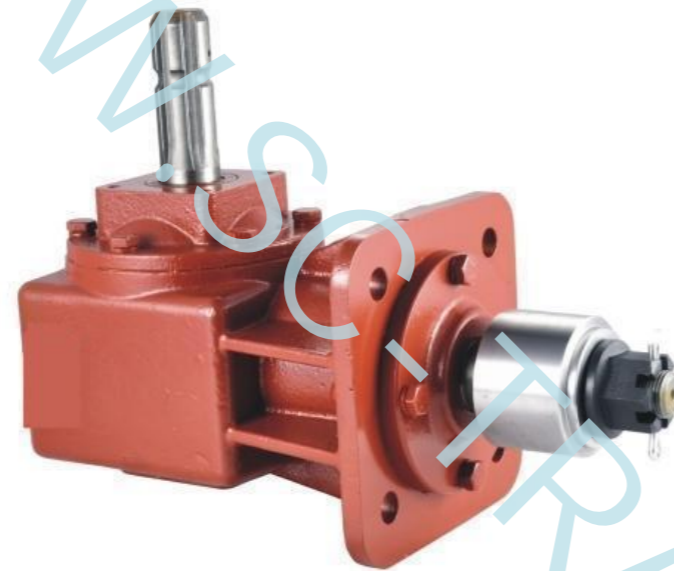
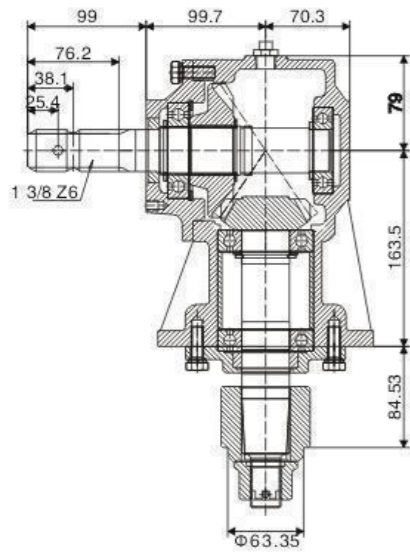

HC-RC33

PRODUCT PARAMETERS

ITEM	HC-RC33
Ratio	1:93 / 1:1.69 / 1:1.47
Teeth	15/29 / 13/22 / 15/22
Module	4.0 / 5.0 / 5.08
Power(HP)	30 / 30 / 30
Rated Input	540 rpm
Input/Output Description	1 3/8 Z6 /Optic axis
Weight(N.W)	26 Kg

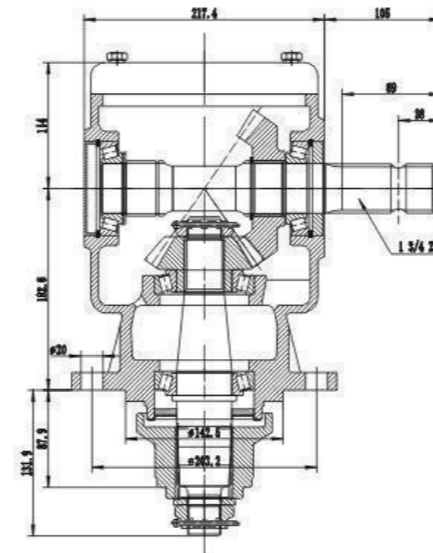

HC-01-707

ITEM	HC-01-707
Ratio	1:1.44
Teeth	23/16
Module	6
Power(HP)	60
Rated Input	540 rpm
Input/Output Description	1 3/4 Z20 / Taper spline
Weight(N.W)	37 Kg

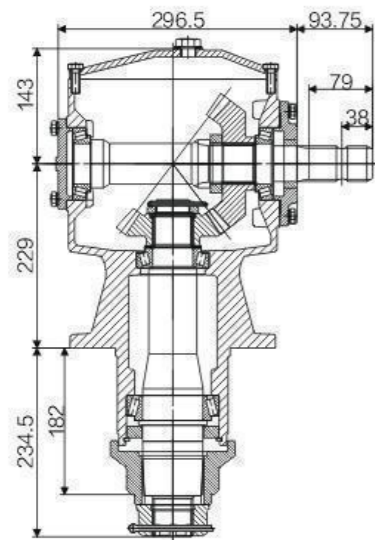

HC-01-768

PRODUCT PARAMETERS

ITEM	HC-01-768 / HC-01-770
Ratio	1:1.93 / 1:1
Teeth	23/12 / 22/22
Module	8 / 8
Power(HP)	150 / 150
Rated Input	540 rpm
Input/Output Description	1 3/4 Z20 / Taper spline
Weight(N.W)	73 Kg

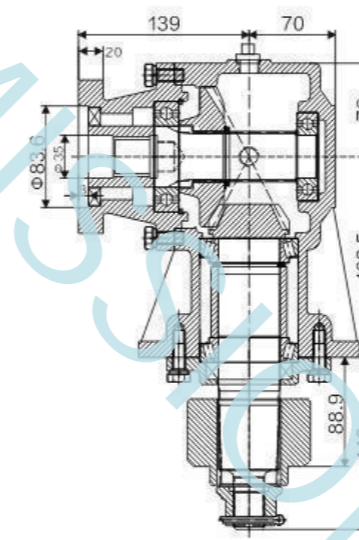

HC-RC51

PRODUCT PARAMETERS

ITEM	HC-RC51
Ratio	1:1.47 / 1:1.93
Teeth	22/15 / 29/15
Module	5.08 / 4.0
Power(HP)	50
Rated Input	540 rpm
Input/Output Description	Spline /Taper spline
Weight(N.W)	29Kg

# Rotary

Cultivator Series

HC-75

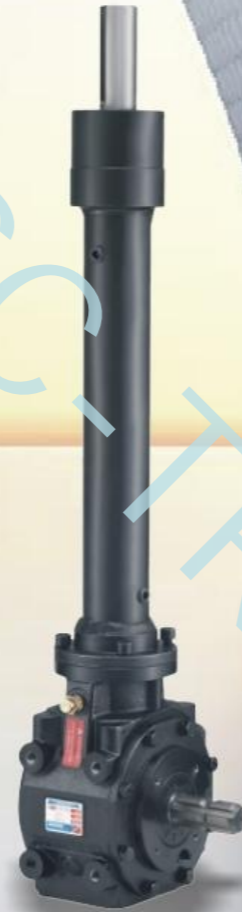

# GEARBOX

Rotary cultivator series

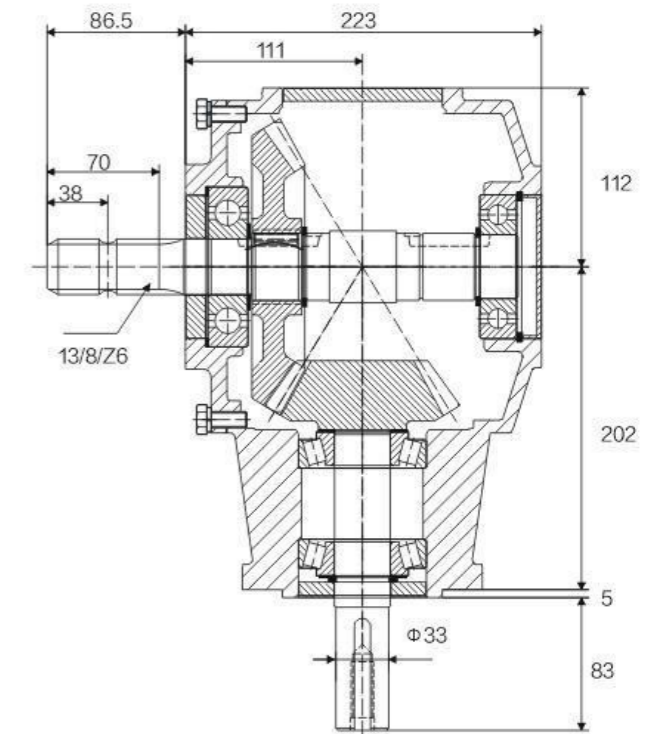

PRODUCT PARAMETERS	
ITEM	HC-75
Ratio	1:3 / 1:2.83 / 1:1.65 / 1:1.6
Teeth	12/36 / 34/12 / 33/20 / 24/15
Module	6.0 / 5.35 / 5.5 / 7.5
Power(HP)	75/75/100/125
Rated Input	540 rpm
Input/Output Description	3/8 Z6 / Optic axis
Weight(MW)	37Kg

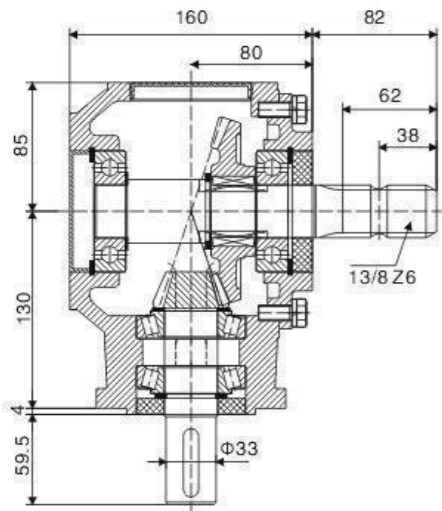

HC-9.310

PRODUCT PARAMETERS

ITEM	HC-9.310
Ratio	1:3
Teeth	12/36
Module	3.45
Power(HP)	30
Rated Input	540rpm
Input/Output Description	13/8 Z6 / Optic axis
Weight(N.W)	18Kg

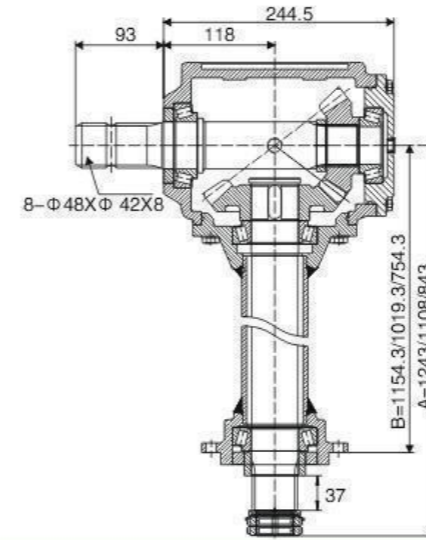

HC20100.131.00

PRODUCT PARAMETERS

ITEM	HC20100.131.00
Ratio	1.31:1
Teeth	16/21
Module	7.0
Power(HP)	100
Rated Input	600rpm
Input/Output Description	8-φ 48X φ 42X8.
Weight(N.W)	58Kg

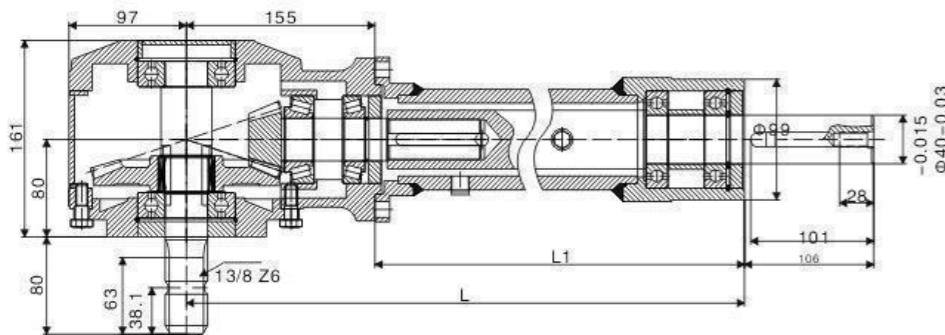

HC-9.311-JCG

PRODUCT PARAMETERS

ITEM	HC-9.311-JCG
Ratio	1:3
Teeth	36/12
Module	4.35
Power(HP)	50
Rated Input	540rpm
Input/Output Description	13/8 Z6 / Optic axis / Optic axis
Weight(N.W)	41Kg

length	SERIES													
	-1	-2	-3	-4	-5	-6	-7	-8	-9	-10	-11	-12	-13	-14
L	375	500	615	670	700	780	810	950	1060	1140	1200	1250	1350	1500
L1	220	345	460	515	545	625	655	795	905	985	1045	1095	1195	1345

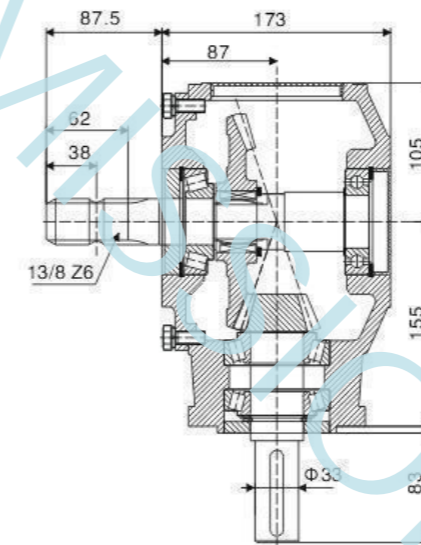

HC-9.312

PRODUCT PARAMETERS

ITEM	HC-9.312
Ratio	1:3
Teeth	12/36/4.58
Module	4.58
Power(HP)	62
Rated Input	540rpm
Input/Output Description	13/8 Z6 / Optic axis
Weight(N.W)	27Kg



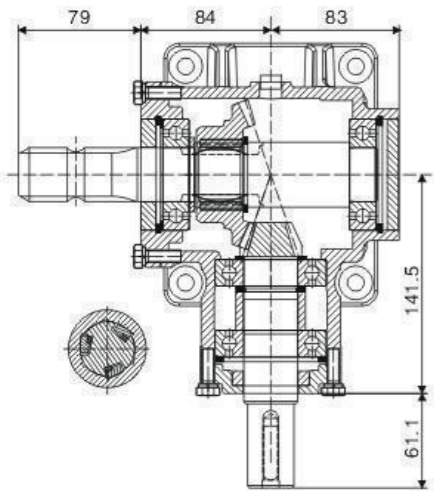

HC30

PRODUCT PARAMETERS

ITEM	HC30
Ratio	1:2.9
Teeth	32/11
Module	3.0
Power(HP)	30
Rated Input	540 rpm
Input/Output Description	1 3/8 Z6 Optic axis
Weight(N.W)	13.5Kg

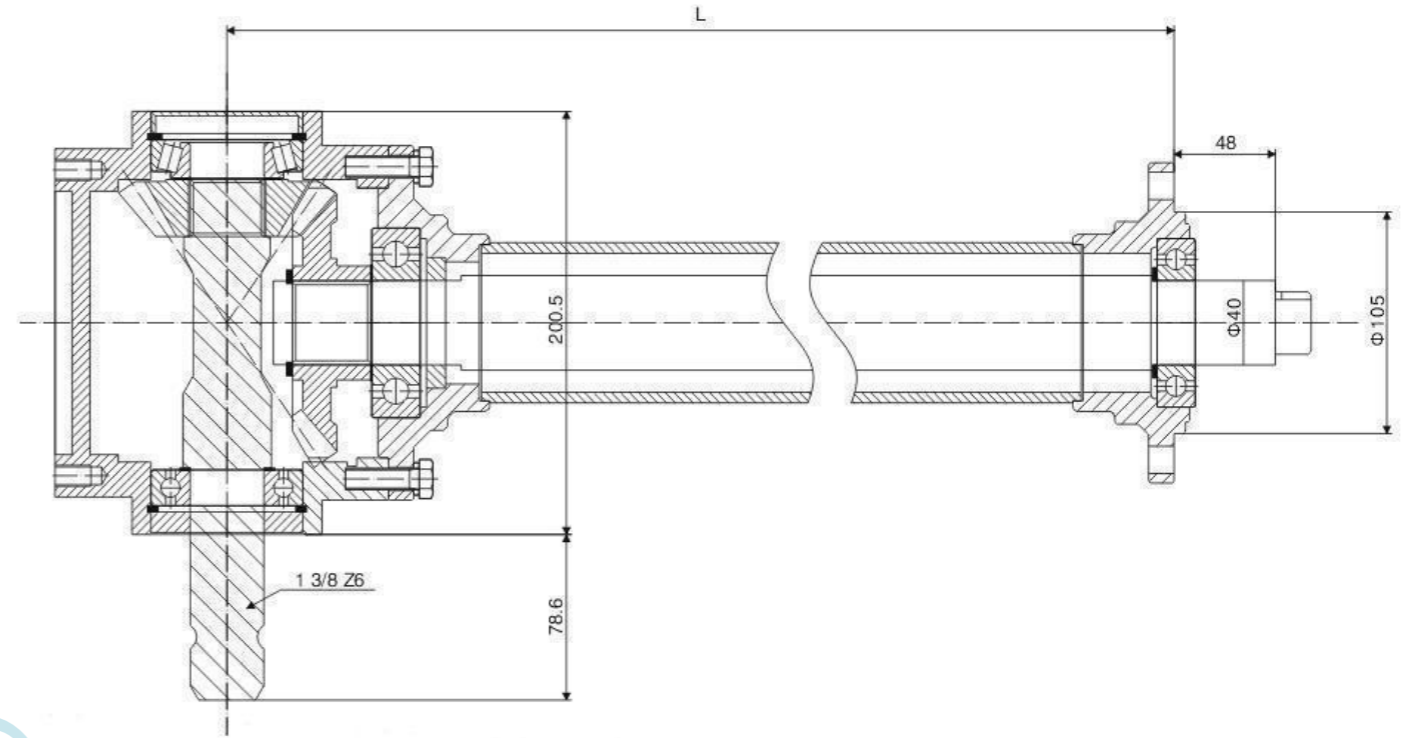

HC-RTM130

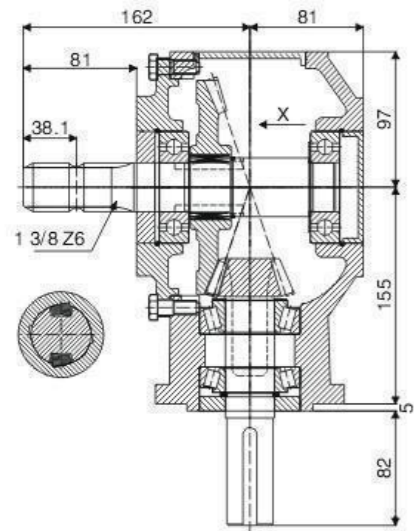

HC-9.311

PRODUCT PARAMETERS

ITEM	HC-9.311
Ratio	1:3
Teeth	36/12
Module	4.35
Power(HP)	50
Rated Input	540 rpm
Input/Output Description	1 3/8 Z6 Optic axis / Optic axis
Weight(N.W)	21Kg

型号	RTM (DR) 105	RTM (DR) 120	RTM (DR) 130	RTM (DR) 135	RTM (DR) 150	RTM (DR) 165	
长度L	524	599	649	674	749	824	
传动比 i	输入转速 r.p.m	输入功率		Z1	Z2	M	重量 kg
1:1.46	540	HP	Kw	15	22	6.0	31

# GEARBOX

Aluminum box series



HC-RV022 (X)

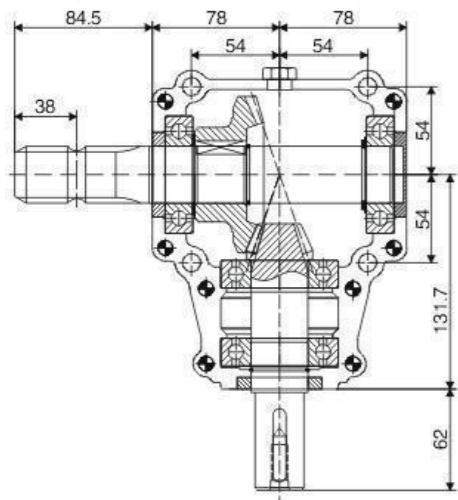

PRODUCT PARAMETERS	
ITEM	HC-RV022 (X)
Ratio	1:1 / 1.46:1 / 1:2.91
Teeth	19/19 / 19/13 / 32/11
Module	4.5 / 5.0 / 3.0
Power(HP)	15
Rated Input	540 rpm
Input/Output Description	1 3/8 Z6 Optic axis
Weight(N.W)	7Kg

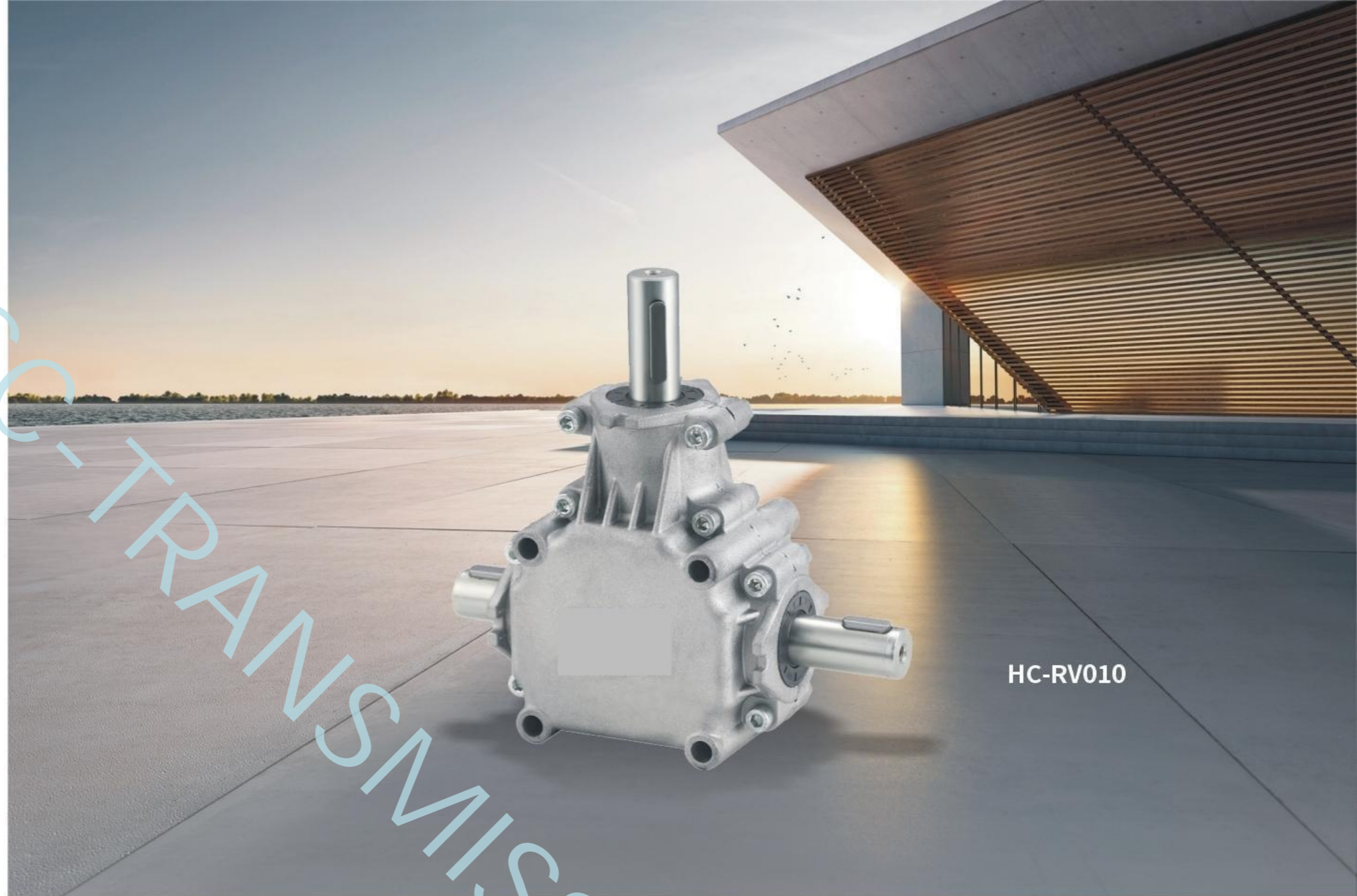

HC-RV010

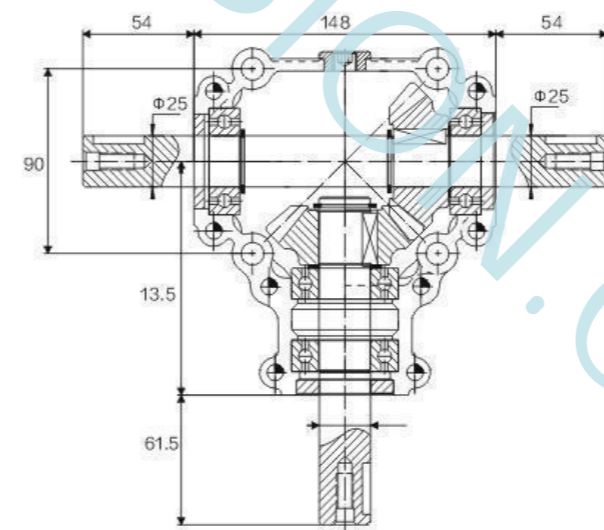

PRODUCT PARAMETERS	
ITEM	HC-RV010
Ratio	1:1 / 1:1.35 / 1:1.9 / 3.3:1
Teeth	16/16 / 17/23 / 10/19 / 10/33
Module	4.5/3.5/4.5/2.5
Power(HP)	15/13/15/3
Rated Input	450rpm
Input/Output Description	1 3/8 Z6 /Optic axis
Weight( N.W)	4Kg

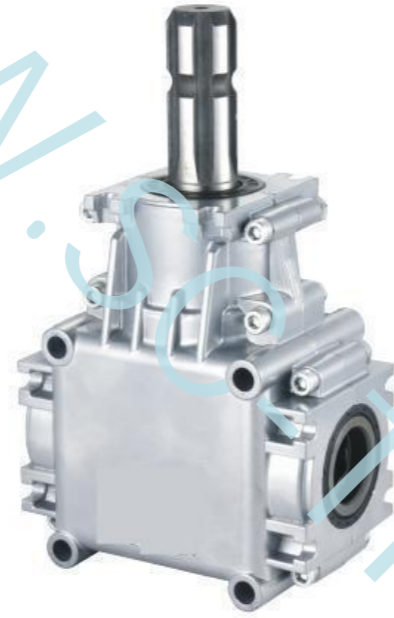
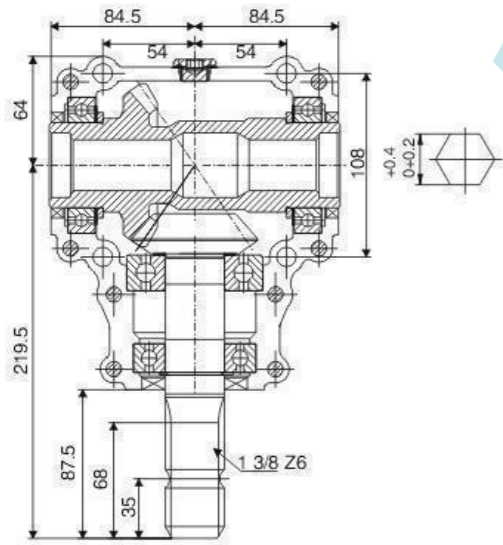

HC-01-674

**PRODUCT PARAMETERS**

ITEM	HC-01-674
Ratio	1.46:1
Teeth	19/13
Module	5
Power(HP)	23
Rated Input	540 rpm
Input/Output Description	1 3/8 Z6
Weight(N.W)	7.2Kg

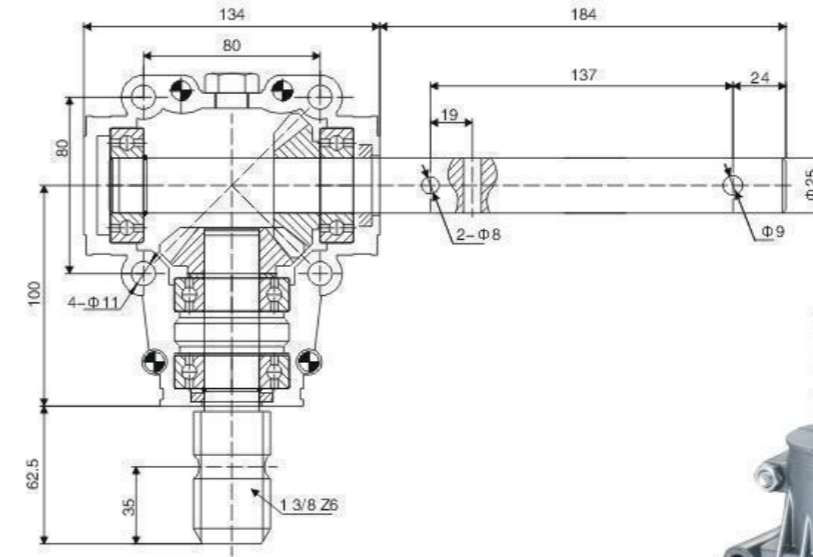

HC-RV012

**PRODUCT PARAMETERS**

ITEM	HC-RV012
Ratio	1:1
Teeth	15/15
Module	4.5
Power(HP)	10
Rated Input	540 rpm
Input/Output Description	1 3/8 Z6
Weight(N.W)	4Kg

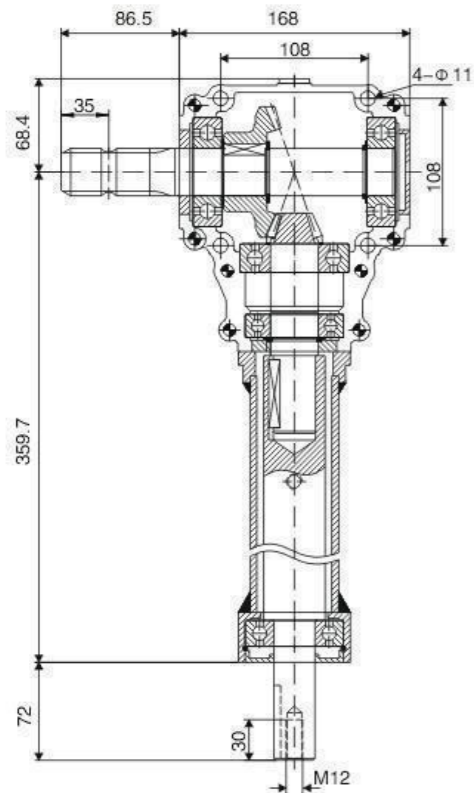

HCAM281-874

**PRODUCT PARAMETERS**

ITEM	HCAM281-874
Ratio	1:2.91
Teeth	32/11
Module	3.0
Power(HP)	13
Rated Input	540 rpm
Input/Output Description	1 3/8 Z6
Weight(N.W)	19 Kg

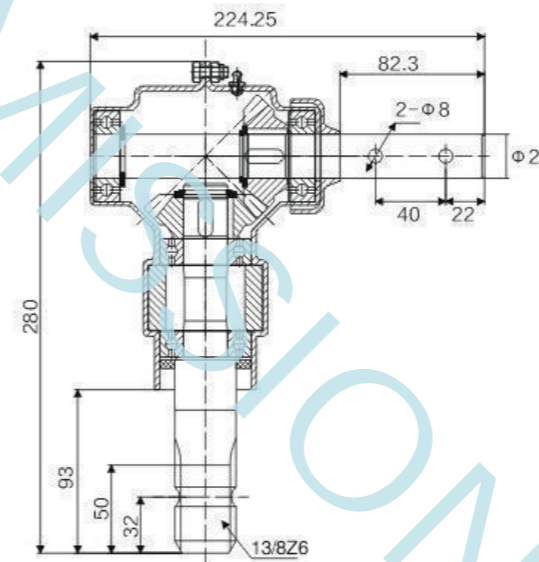

HC-01-229

**PRODUCT PARAMETERS**

ITEM	HC-01-229
Ratio	1:1
Teeth	16/16
Module	4.5
Power(HP)	15
Rated Input	540 rpm
Input/Output Description	1 3/8 Z6 φ25 Optic axis
Weight(N.W)	13Kg

# GEARBOX

PIT DIGGER



HC-01-724



HC-GT40U

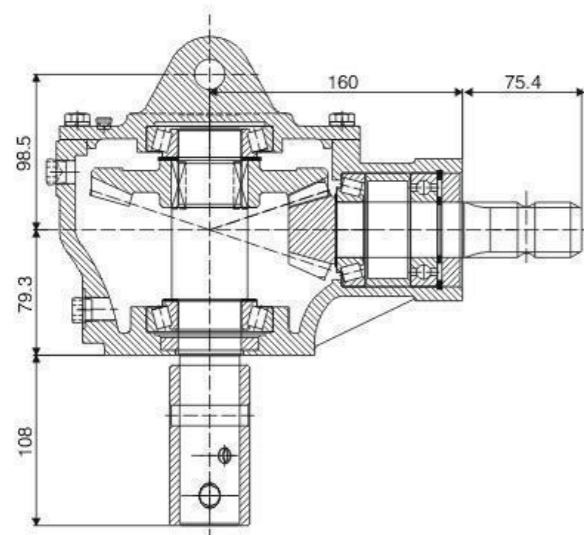

PRODUCT PARAMETERS	
ITEM	HC-01-724
Ratio	3:1
Teeth	10/30
Module	5.0
Power(HP)	30
Rated Input	540rpm
Input/Output Description	13/8 Z6 Optic axis
Weight(N.W)	19Kg

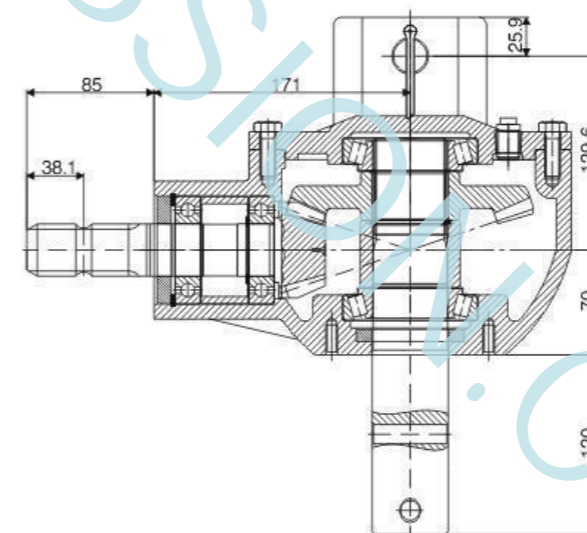

PRODUCT PARAMETERS	
ITEM	HC-GT40U
Ratio	3:1
Teeth	33/11
Module	5.0
Power(HP)	45
Rated Input	540 rpm
Input/Output Description	13/8 Z6 Optic axis
Weight(N.W)	28 Kg

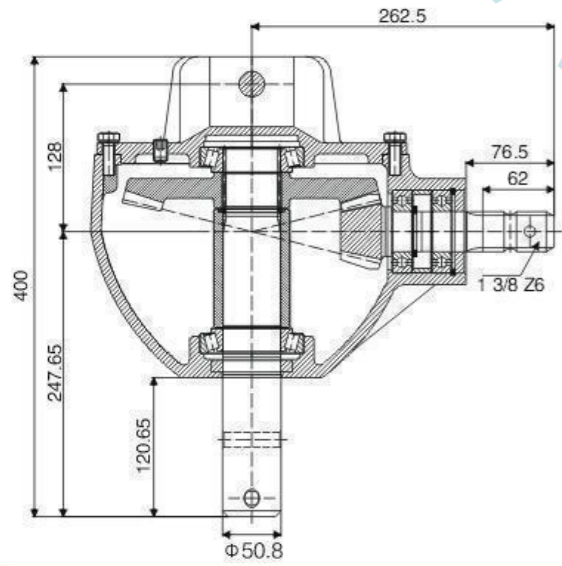

ITEM	HC-01-084
Ratio	4:1
Teeth	11/44
Module	5.0
Power(HP)	50
Rated Input	540 rpm
Input/Output Description	1 3/8 Z6/Optic axis
Weight(N.W)	44 Kg



HC-01-084

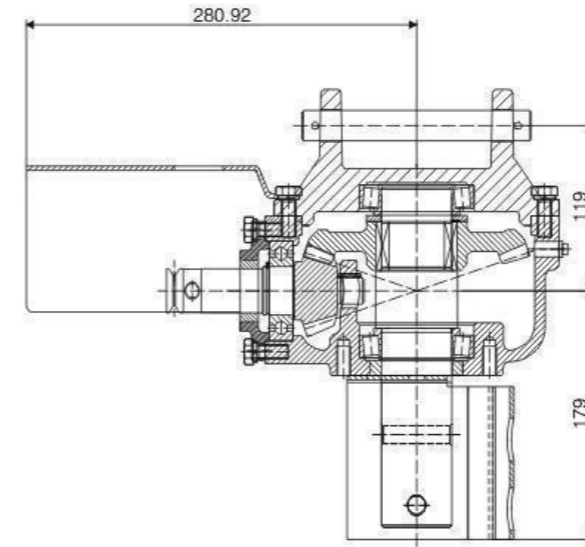

PRODUCT PARAMETERS

ITEM	HC-650PHD
Ratio	2.92:1
Teeth	13/38
Module	4.25
Power(HP)	30
Rated Input	540 rpm
Input/Output Description	Optic axis
Weight(N.W)	21.8 Kg



HC-650PHD

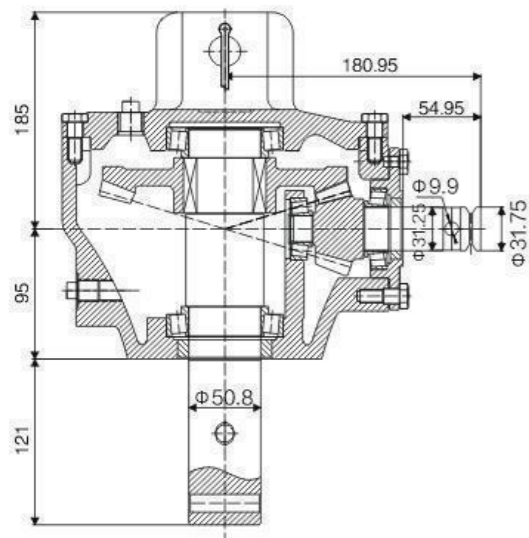

PRODUCT PARAMETERS

ITEM	HC-01-725
Ratio	3.18:1
Teeth	11/35
Module	5.08
Power(HP)	40
Rated Input	540 rpm
Input/Output Description	Optic ax1S
Weight(N.W)	28Kg



HC-01-725

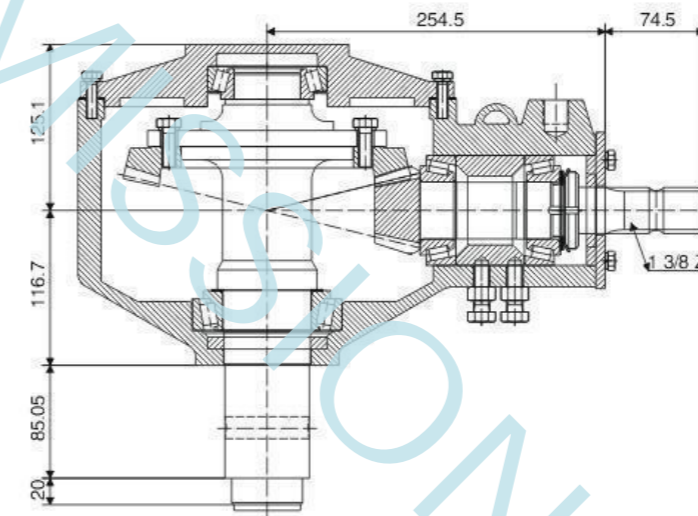

PRODUCT PARAMETERS

ITEM	HC-2300058
Ratio	4.08:1
Teeth	12/49
Module	4.5
Power(HP)	50
Rated Input	540 rpm
Input/Output Description	1 3/8 Z6 / Optic axis
Weight(N.W)	59 Kg



HC-2300058

# GEARBOX

Lawn mower series



HC-BGB9

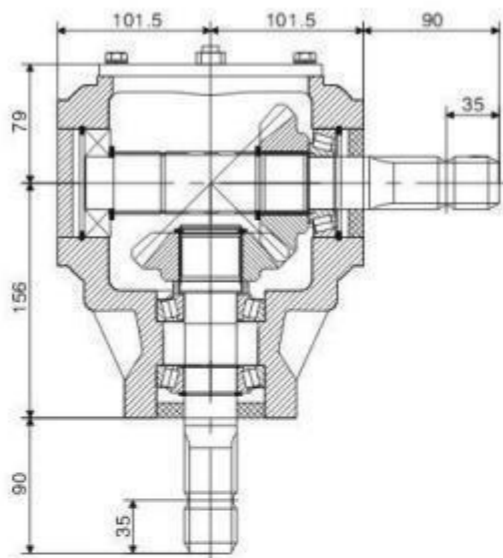

PRODUCT PARAMETERS	
ITEM	HC-BGB9
Ratio	1:1 / 1:1.35 / 1:1.46 / 1:2
Teeth	16/16 / 23/17 / 22/15 / 15/30
Module	6.35 / 5.0 / 5.0 / 3.5
Power(HP)	30
Rated Input	540 rpm
Input/Output Description	1 3/8 Z6 / 13/8Z6 Opticaxis
Weight(N.W)	23 Kg



HC-9.259

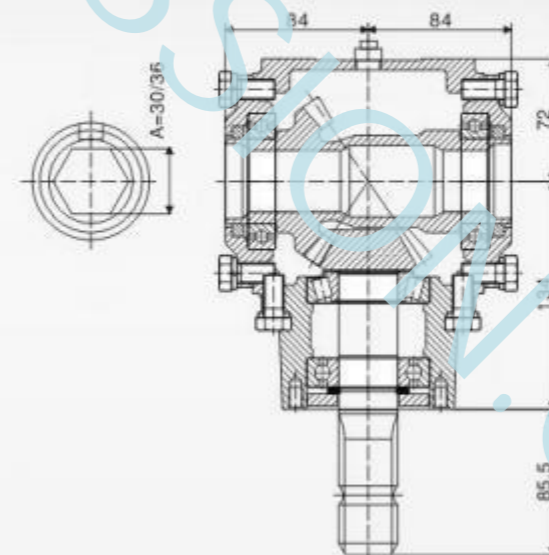

PRODUCT PARAMETERS	
ITEM	HC-9.259
Ratio	1.46:1
Teeth	19/13
Module	5.0
Power(HP)	30
Rated Input	540 rpm
Input/Output Description	1 3/8 Z6 Opticaxis
Weight(N.W)	14 Kg

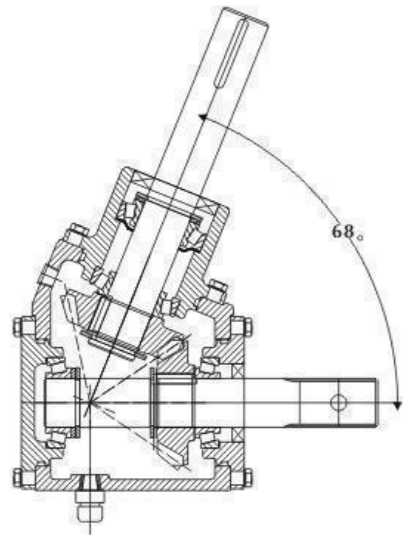

PRODUCT PARAMETERS	
ITEM	HC-68°
Ratio	1:1
Teeth	19/19
Module	4.23
Power(HP)	30
Rated Input	540 rpm
Input/Output Description	0 ptic axis/ Spline .
Weight(N.W)	13.2 Kg



HC-68°

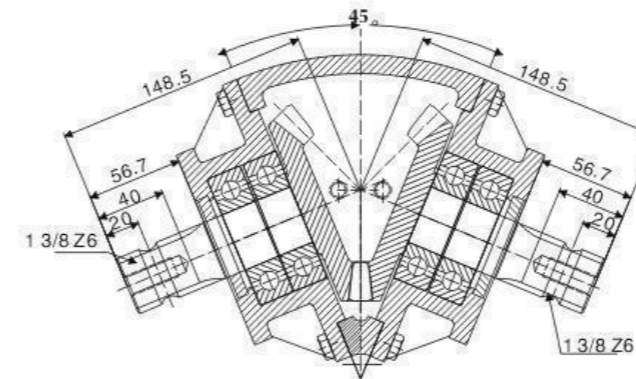

PRODUCT PARAMETERS	
ITEM	HC-AG135
Ratio	1:1
Teeth	20/20
Module	6.0
Power(HP)	50
Rated Input	540 rpm
Input/Output Description	1 3/8 Z6 Cone base aequilate spline shaft
Weight(N.W)	16.5Kg



HC-AG135

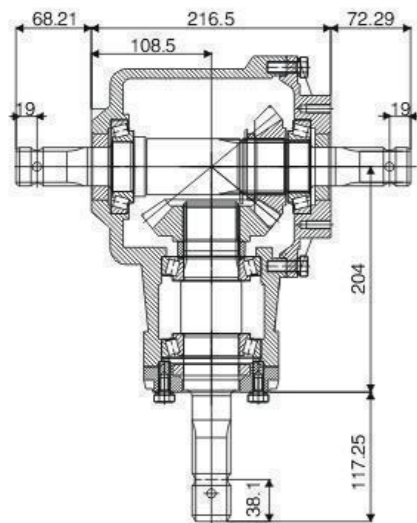

PRODUCT PARAMETERS	
ITEM	HC-RC61T
Ratio	1:1 / 1:1.21 / 1:1.46 / 1:1.93
Teeth	16/16 / 17/14 / 19/13 / 27/14
Module	7.0 / 7.0 / 7.0 / 5.5
Power(HP)	60
Rated Input	540rpm
Input/Output Description	1 3/8 Z6 / 1 3/8 Z6
Weight(N.W)	33.5 Kg



HC-RC61T

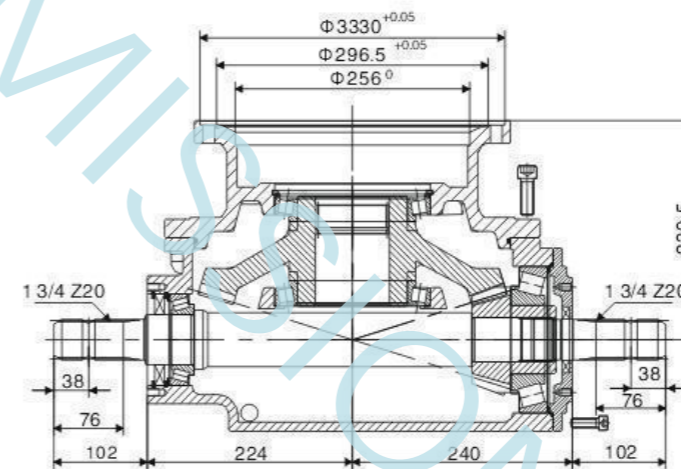

PRODUCT PARAMETERS	
ITEM	HC-40002
Ratio	3.2:1 / 3.77:1 / 4.17:1
Teeth	15/48 / 13/49 / 12/50
Module	15/48 / 13/49 / 12/50
Power(HP)	85 / 85/85
Rated Input	540 rpm
Input/Output Description	1 3/4 Z6
Weight(N.W)	111 Kg



HC-40002

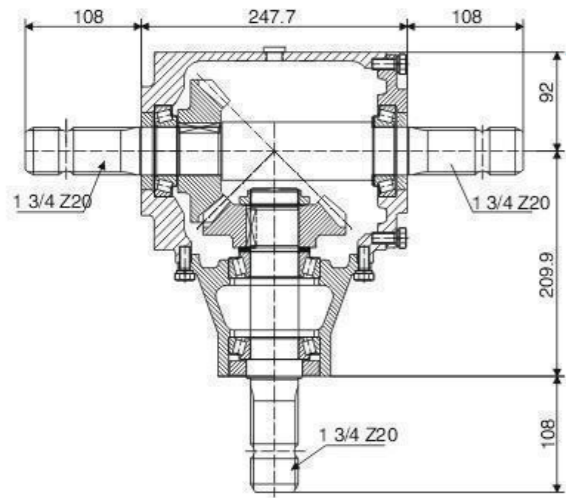

PRODUCT PARAMETERS

ITEM	HC-9.279
Ratio	1:1.5 / 1:1
Teeth	27/18 / 22/22
Module	5.7 / 6
Power(HP)	100 / 120
Rated Input	540 rpm
Input/Output Description	1 3/4 Z20
Weight(N.W)	38Kg



HC-9.279

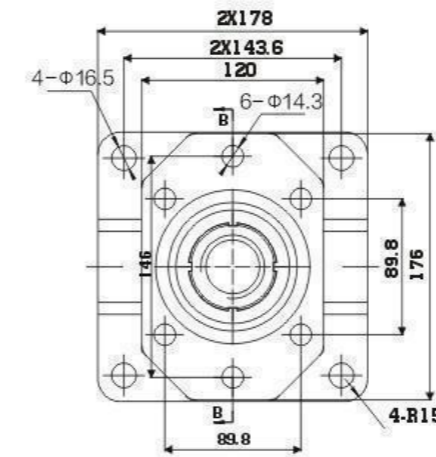
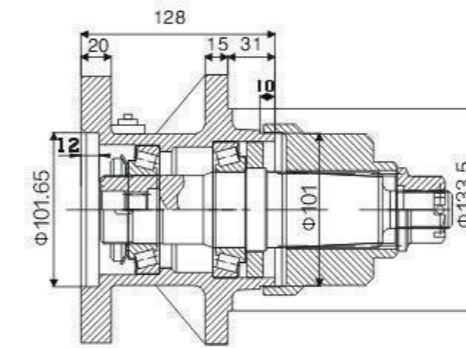

HC-MDH-40

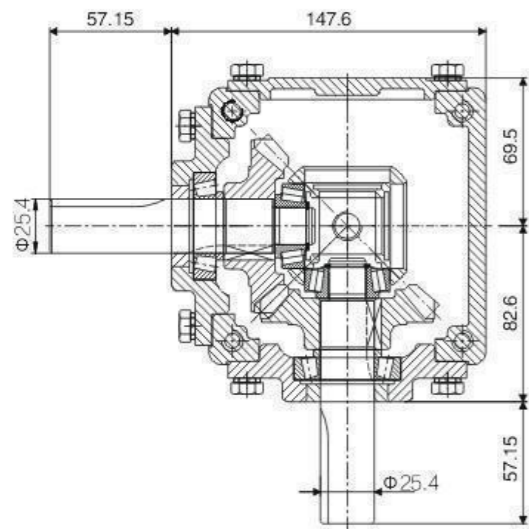

PRODUCT PARAMETERS

ITEM	HC-19455-KW
Ratio	1:1
Teeth	19/19
Module	4.23
Power(HP)	20
Rated Input	540 rpm
Input/Output Description	Φ25 Optical axis
Weight(N.W)	9 Kg



HC-19455-KW

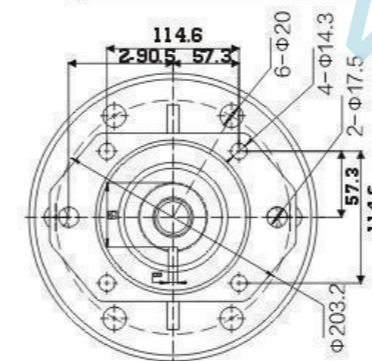
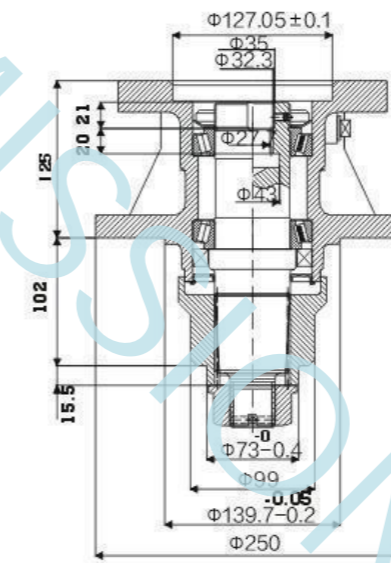

HC-MDH-65



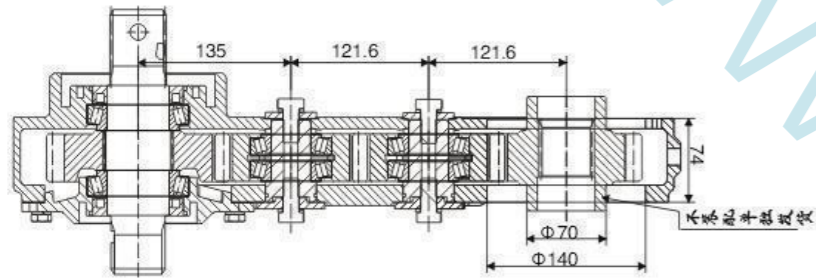

HC-1ZS-380

PRODUCT PARAMETERS

ITEM	HC-1ZS-380
Ratio	1:1.24
Teeth	21/17/17/17
Module	7.0
Power(HP)	100
Rated Input	540 rpm
Input/Output Description	Spline
Weight(N.W)	42.5 Kg

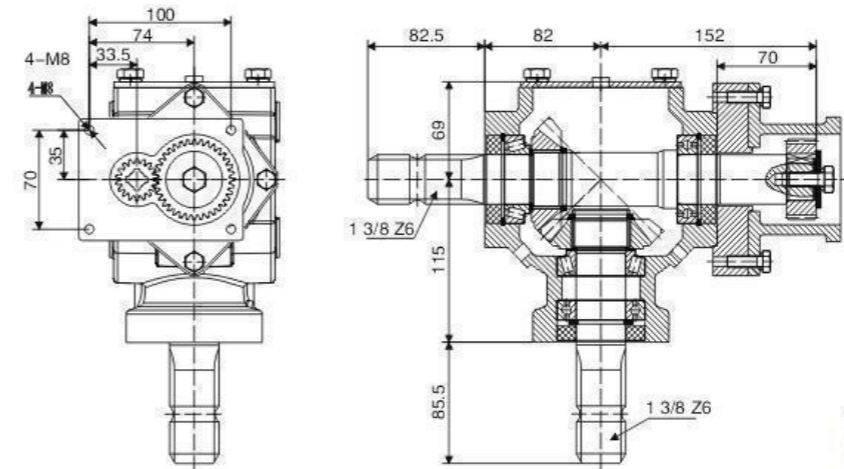

HC20.100J.01WW

PRODUCT PARAMETERS

ITEM	HC20.100J.01WW
Ratio	1:1
Teeth	15/15
Module	5.4
Power(HP)	30
Rated Input	540 rpm
Input/Output Description	1 3/8 Z6
Weight(N.W)	16Kg

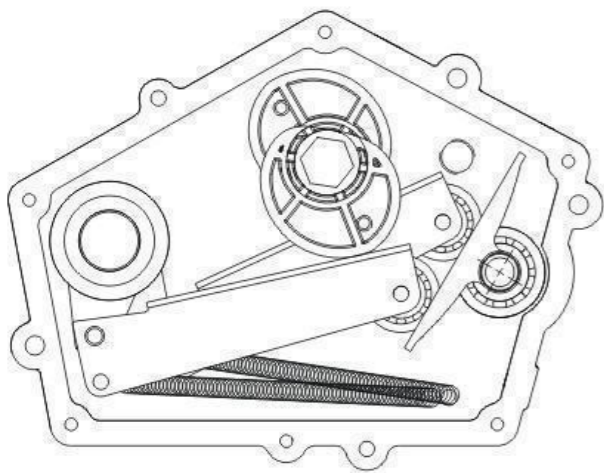

HC01-778

PRODUCT PARAMETERS

ITEM	HC-01-778
Ratio	0:1 / 3.35:1
Rated Input	540 rpm
Input/Output Description	φ 20
Weight(N.W)	11.5Kg

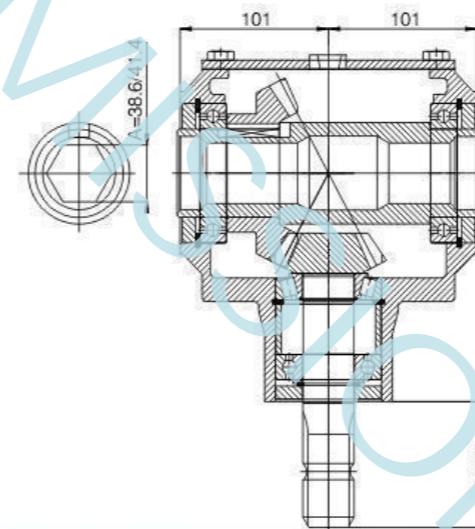

HC01-672

PRODUCT PARAMETERS

ITEM	HC01-672
Ratio	1.92:1 / 1.47:1
Teeth	23/12 / 22/15
Module	5.5 / 5.65
Power(HP)	40
Rated Input	540 rpm
Input/Output Description	1 3/8 Z6/Optic axis
Weight(N.W)	18.5 Kg

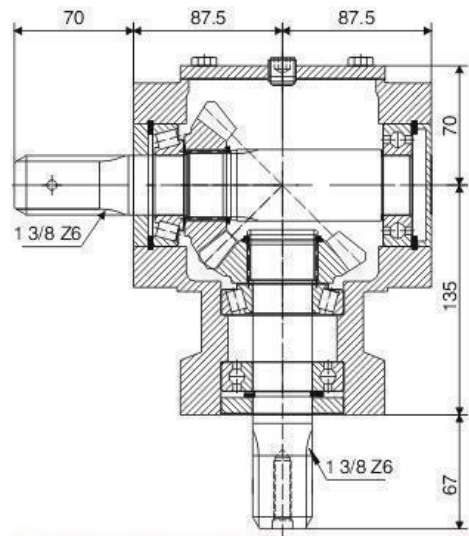

**PRODUCT PARAMETERS**

ITEM	HC-BGB8
Ratio	1:1 / 1.67:1
Teeth	22/15 / 15/25
Module	5.08 / 4.0
Power(HP)	30
Rated Input	540 rpm
Input/Output Description	1 3/8 Z6 / 1 3/8 Z6
Weight(N.W)	18 Kg



HC-BGB8

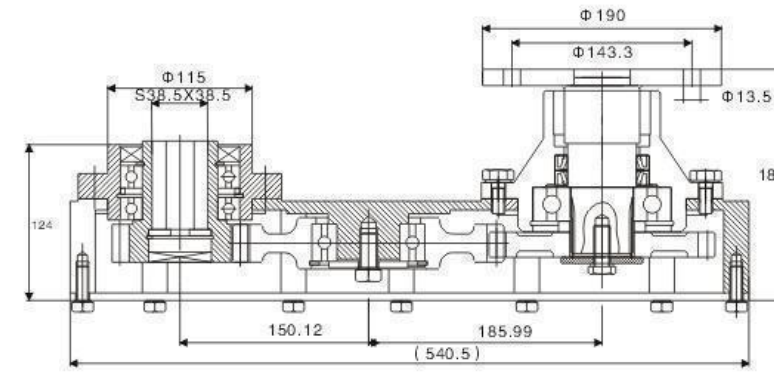

HC-RTS50

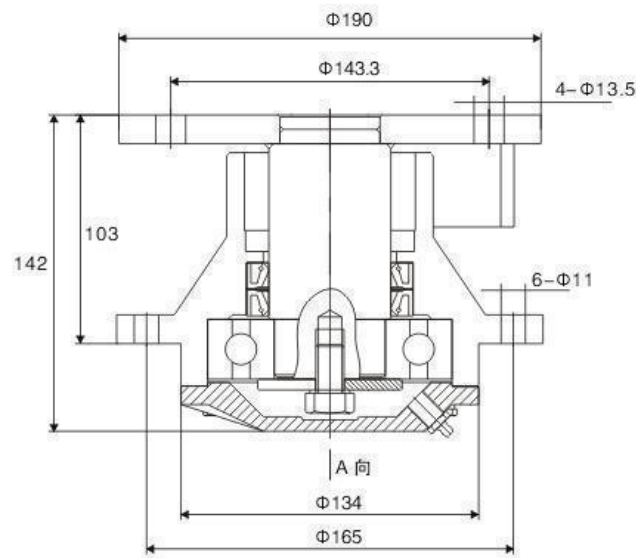

HC-RTD50

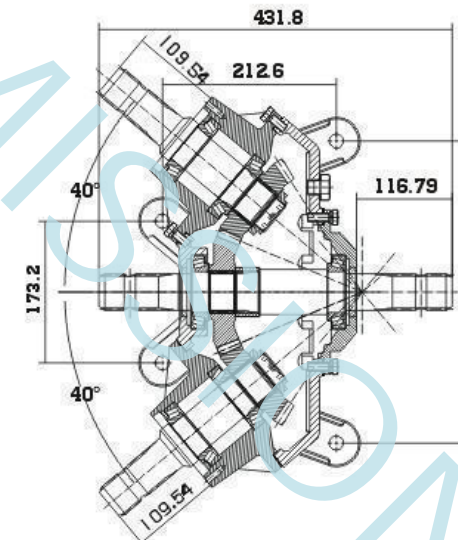

HC 01 661

**PRODUCT PARAMETERS**

ITEM	HC 01 661
Ratio	1:1.3
Teeth	26/20
Module	5.644
Power(HP)	80
Rated Input	540 rpm
Input/Output Description	1 3/4 Z20
Weight(N.W)	57.5Kg



HC 01 662